



# Mandozine

Learning all the notes on the fretboard can be a little intimidating. The best way to learn the notes is to start with a few notes on one string (this document presents groups of six). If six is too much to start, learn the notes in groups of three. Even if you just learn half the fretboard, frets 1 to 6, you will benefit. One reason to learn the fretboard is to be able to find the root note of a chord. This is needed in playing movable chords. It's beneficial to learn chords, or the root note of chords you already know, in context of learning the fretboard. I have include one chord for each fret note. These are movable chords.

Once you learn a chord for a specific fret, you can simply move the chord up or down a fret, and that chord will be the name of the note on the new fret. If you learn all six chords, and the six notes, you will have learned 36 chords, but only six chords shapes. The red dot represents the root note of the chord.

## G String - Frets 1-6

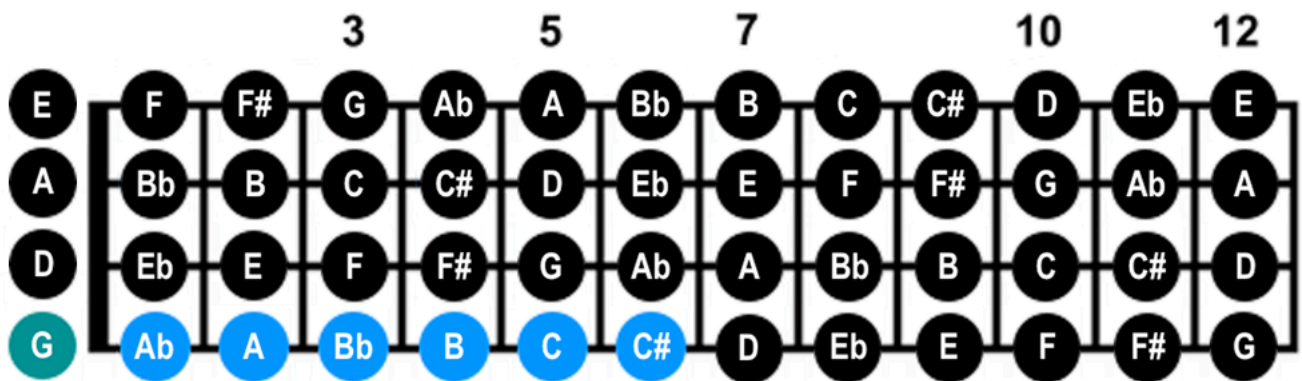

Fret	1	2	3	4	5	6
<b>4th String</b>	<b>Ab</b>	<b>A</b>	<b>Bb</b>	<b>B</b>	<b>C</b>	<b>C#</b>
	Ab	A7	Bbm	Bm7	Cmaj7	C#6













# Mandozine

## A String - Frets 7-12

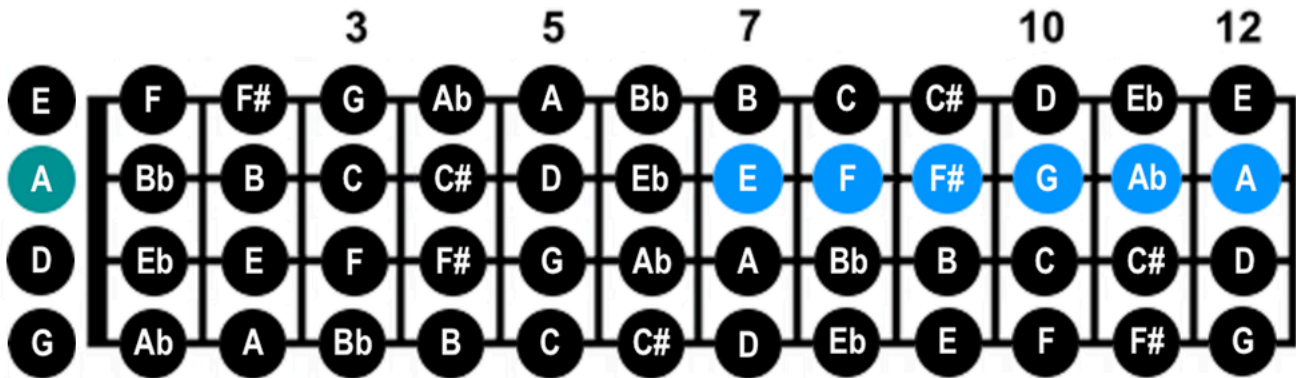

Practice the chords below, memorizing the chord shapes and the root note string. As you learn the fret notes, move the chords up and down the neck identifying the chord name by the fret note.

Fret	7	8	9	10	11	12
2nd String	E	F	F#	G	A <sub>b</sub>	A
	E	F7	F#m	G6	A <sub>b</sub> m6	Asus4







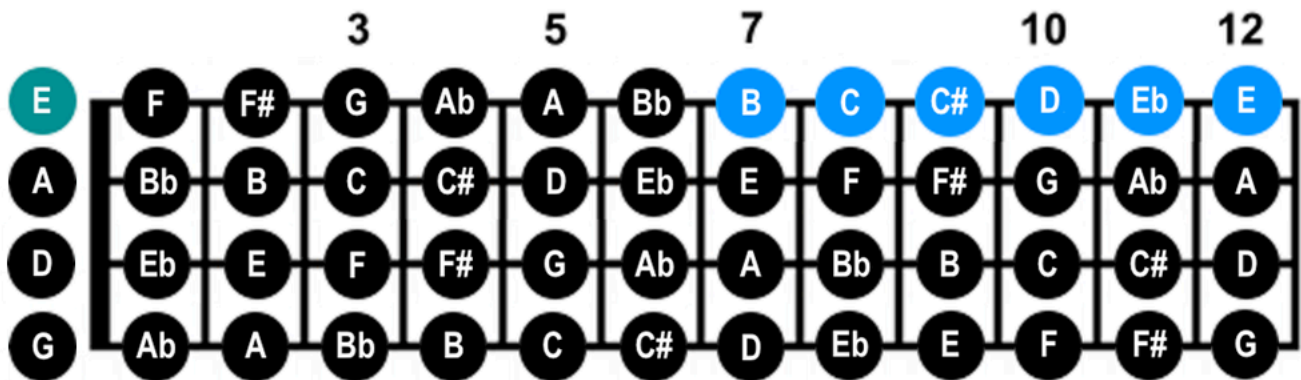

# Mandozine

## E String - Frets 7-12



Practice the chords below, memorizing the chord shapes and the root note string. As you learn the fret notes, move the chords up and down the neck identifying the chord name by the fret note.

Fret	7	8	9	10	11	12
1st String						
	B	C7	C#m	D7b5	Eb7b9	Em7
	